

# twilight

INSTRUMENTOS DE MEDICIÓN INDUSTRIAL

**Medidor de Altura 12"**

**FW-521742120**

[www.twilight.mx](http://www.twilight.mx)

 / [twightsadecv](#)

 / [twightsadecv](#)

 / [twightsadecv](#)



# Double Column Height Dial Gage Operating Instructions

The height gage will be read with dual directional counters in combination with a dial. The dual directional counters can be set at any desired height by depressing the zero set button.

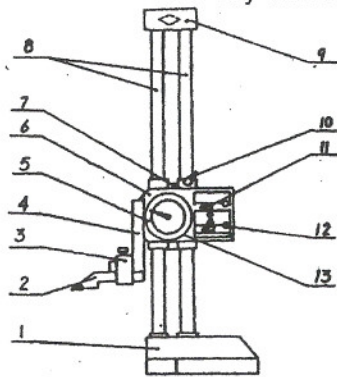

Fig. 1

- |                          |                          |
|--------------------------|--------------------------|
| (1) Base                 | (8) Columns              |
| (2) Scriber              | (9) Fixing Piece         |
| (3) Clamp                | (10) Locking Lever       |
| (4) Scribing Frame       | (11) Counter             |
| (5) Dial                 | (12) Zero Setting Button |
| (6) Carriage             | (13) Dial Bezel          |
| (7) Measuring Hand Wheel |                          |

## 1. SPECIFICATIONS

- 1.1 Measuring range: 0-300mm, 0-450mm, 0-600mm, 0-12in, 0-18in, 0-24in
- 1.2 Graduations
  - 1.2.1 Dial graduations: 0.01mm, 0.001in
  - 1.2.2 Counter graduations: 1mm, 0.1in
- 1.3 Range/Rev: 1mm, 0.1in
- 1.4 Accuracy

Accuracy		Accuracy	
0-200mm	±0.03mm	0-8in	±0.0012in
>200-400mm	±0.04mm	>8-16in	±0.0015in
>400-600mm	±0.05mm	>16-24in	±0.002in

## 2. HOW TO TAKE MEASUREMENTS

- 2.1 Setting Zero.
  - 2.1.1 Keep base and the surface of the scriber clean before measuring.
  - 2.1.2 Loosen the locking lever.
  - 2.1.3 Turn the measuring handwheel.
    - a. Course adjustment: Turn the small handle. Fig.2.
    - b. Fine adjustment: Turn the large handwheel lightly, contact the scriber to the reference face. Fig. 3.
  - 2.1.4 Turn the dial bezel to the "0" position.
  - 2.1.5 Press the two zero setting buttons on the counters to set them to "0."
- 2.2 One may now perform height measurements and scribing.
- 2.3 Methods of reading.
  - 2.3.1 From a reference face to a height measurement, the measured value should be the upper counter's reading plus the reading of the dial.
  - 2.3.2 To measure down from certain reference, the measured value should be the lower counter's reading plus the reading of the dial.
  - 2.3.3 Comparison Measurement: First, measure a reference workpiece with the height gage, turn the dial bezel to set the "0" position, then measure a workpiece and read on the dial directly.

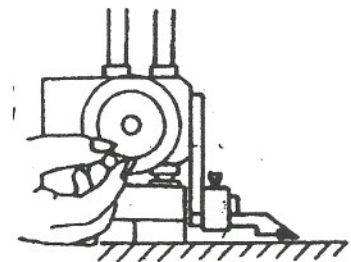

Fig. 2

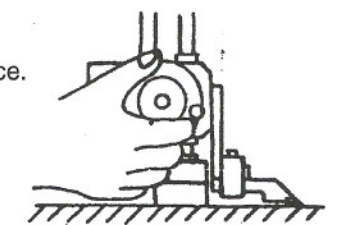

Fig. 3

## 3. NOTES

- 3.1 Keep the tool clean and avoid shocks or accuracy may be affected.
- 3.2 Move the tool by the base, not the columns.
- 3.3 Lower the carriage when not in use, but not lower than the bottom of the base. If the unit will not be used for some time remove the scriber and apply a light coat of oil on all surfaces.
- 3.4 Prevent water or other liquids from entering the carriage.

# twilight

INSTRUMENTOS DE MEDICIÓN INDUSTRIAL



LLÁMANOS

**+52(81) 8115-1400 / +52 (81) 8173-4300**

LADA Sin Costo:  
**01 800 087 43 75**

E-mail:  
**ventas@twilight.mx**

[www.twilight.mx](http://www.twilight.mx)